

OWNER'S MANUAL

Digital Torque Wrench NTW1



Contents

1. Main Features
2. Names and Functions of Parts
3. Specification
4. Before Using the Wrench
5. Setup
6. Track Mode Operation
7. Peak Hold Mode Operation
8. Maintenance and Storage

Dear Customers,

Thank you for purchasing our digital torque wrench. This manual will help you to use the many features of your new digital torque wrench. **Before operating the torque wrench, please read this manual completely**, and keep it nearby for future reference.

MAIN FEATURES

- Adjustable Jaw 5-30 mm
- Digital torque value readout
- +/- 2% accuracy
- Clockwise and Counter Clockwise operation
- Peak hold and track mode selectable
- Buzzer and LED indicator for the 9 pre-settable target torques
- Water contact indicator
- Engineering units (N-m, ft-lb, in-lb, kg-cm) selectable
- 50 data memory for recall and joint torque auditing
- Auto Sleep after about 5 minutes without use

NAMES AND FUNCTIONS OF PARTS

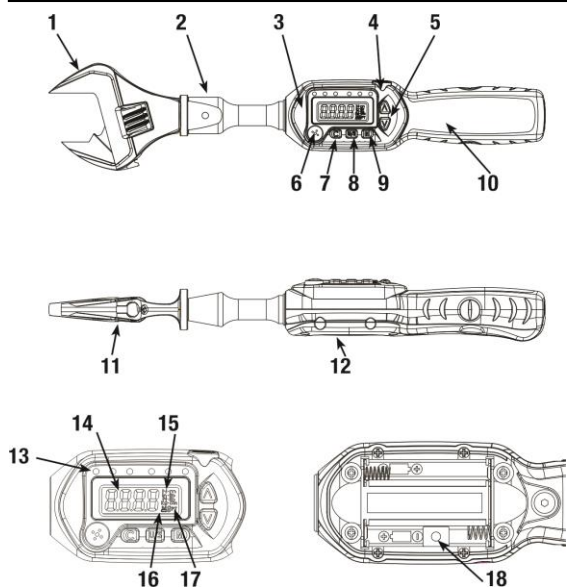

- | | |
|---|---------------------------------------|
| 1. Head Insert | 10. Anti-slip Handle |
| 2. Sensor Yoke | 11. Opening Size Adjuster |
| 3. LCD Readout | 12. Battery Cover |
| 4. Communication Port | 13. LED Indicator |
| 5. Up/Down Button | 14. Torque Value Readout |
| 6. Buzzer | 15. Units(N-m,ft-lb,in-
lb,kg-cm) |
| 7. Power on/Clear Button | 16. Pre-setting Number |
| 8. Unit/Setting Button | 17. Peak/Track Mode |
| 9. Pre-setting Number
Selection Button | 18. Water Indicator Viewing
Window |

SPECIFICATIONS

Model No.	Torque Measuring Range	Jaw Size	Length
NTW1	4.2~85 N-m	5-30mm	12.8 in 325 mm
Accuracy *1	CW : ±2% CCW : ±3%		
Data memory size	50		
Pre-Sets	9		
Bright LED	6 LEDs (1 Red+5 Green)		
Operation Mode	Peak hold/Track		
Unit Selection	N-m, in-lb, ft-lb, kg-cm		
Head Type	Adjustable Jaw		
Battery	AAA x 2		
Operating Temperature	14°F-140°F (-10°C-60°C)		
Storage Temperature	4°F-158°F (-20°C-70°C)		
Humidity	Up to 90% non-condensing		
Drop Test	3.28 ft (1 m)		
Vibration Test *2	10G		
Environmental test *3	Pass		
Electromagnetic compatibility test *4	Pass		

Note:

*1: The accuracy of the readout is guaranteed from 20% to 100% of maximum range + /- 1 increment. The torque accuracy is a typical value. Calibration point is at the middle line of black circle area on the rubber grip. For keeping the accuracy, calibrate the wrench for a constant period time (1 year).

*2: Horizontal and vertical test.

*3: Environmental test:

- a. Dry heat
- b. Cold
- c. Damp heat
- d. Change of temperature
- e. Impact (shock)
- f. Vibration
- g. Drop

*4: Electromagnetic compatibility test:

- a. Electrostatic discharge immunity (ESD)
- b. Radiated susceptibility
- c. Radiated emission

BEFORE USING THE WRENCH

BATTERY INSTALLATION

- Remove the battery cap.
- Insert two AAA batteries matching the -/+ polarities of the battery to the battery compartment.
- Put on the battery cap and fasten it tightly.

ATTENTION:

When opening the battery cover of wrench, you can see a viewing window for the **water contact indicator**. Through this viewing window, you can check if this wrench is damaged by water penetration if the water contact indicator turns red.

POWER ON AND RESETTING THE WRENCH

- Press **C** to power on the digital torque wrench.
- Usually press **C** to reset the digital torque wrench before using it.



ATTENTION:

If an external force is applied to the torque wrench during power-on/reset or wake up period, an initial torque offset will exist in the memory.

ACTIVATION DURING SLEEP MODE

- The wrench will auto sleep after about 5 minutes without use for power saving. Press **C** to wake up the wrench during the sleep mode.

RESETTING THE WRENCH

- If the wrench does not function normally, Press **C** **▲** together to reset the wrench.

LOW BATTERY VOLTAGE PROTECTION

- If the battery serial voltage is in low voltage status, the wrench will display a battery symbol and then turn off after a while.



WHEN CHANGING THE TYPE OF HEAD

- If you use the different head of the wrench, the reading on the display will be different for the different length of the head. Please refer to the following explanation.

$$D = D1 * (L3+L1) / (L3+L2)$$

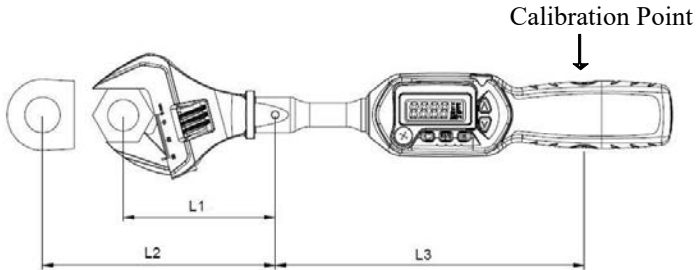

- D : The set torque
- D1: The actual torque applied to the nut.
- L1: The normal length
- L2: The extended length
- L3: The length from the fitting pin to the calibration point.

- Reference dimension for each model :

Model	L1(mm)	L3(mm)
NTW1	85.9	175

SETUP

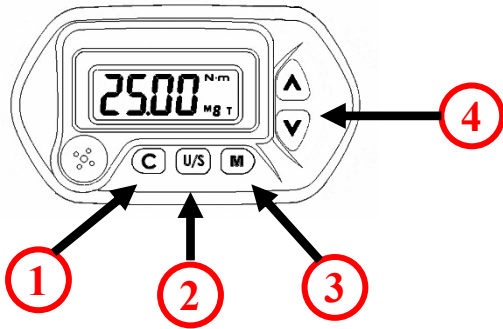

- ① Power On/Clear
- ② Unit Selection/Setting
- ③ Pre-setting No.
- ④ Up/Down Button

STEP 1: PRE-SETTING NO.

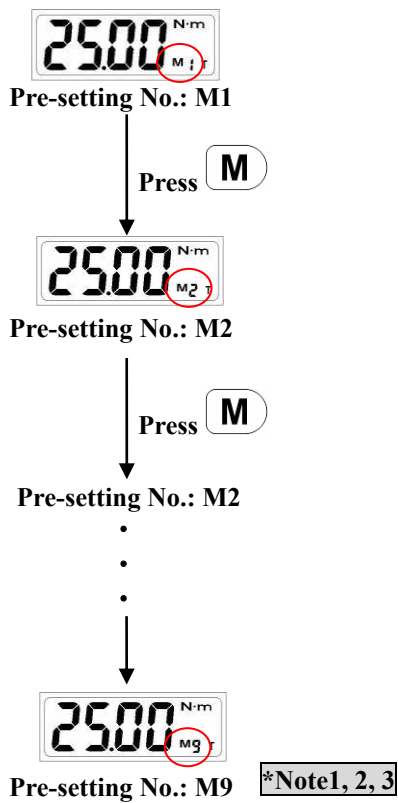

Note:

1. If **Er0** is displayed, that means this wrench has ever been applied more than 110% of torque of the spec.
2. The max number of Pre-Sets is 9.
3. The "Pre-setting No." is cyclic.

STEP 2: UNIT SELECTION

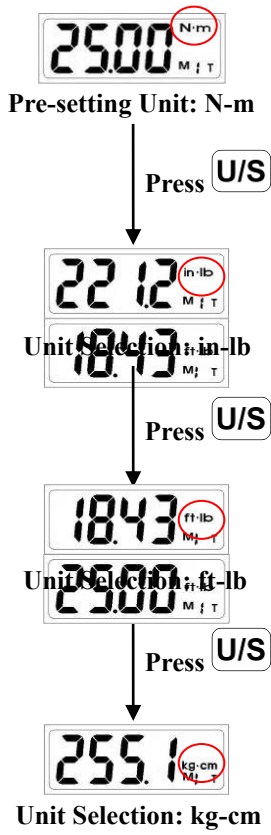

STEP 3: SET TORQUE VALUE

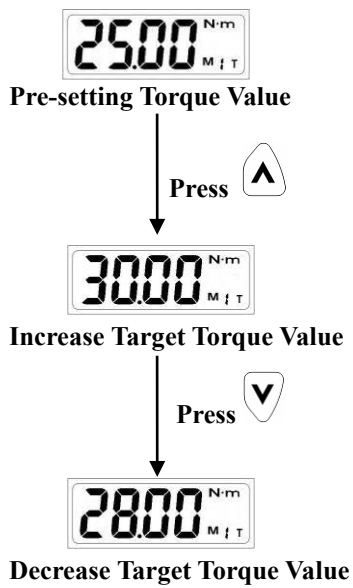

Note:

1. The “Unit Selection” is cyclic.

STEP 4: PEAK HOLD /TRACK MODE SELECTION

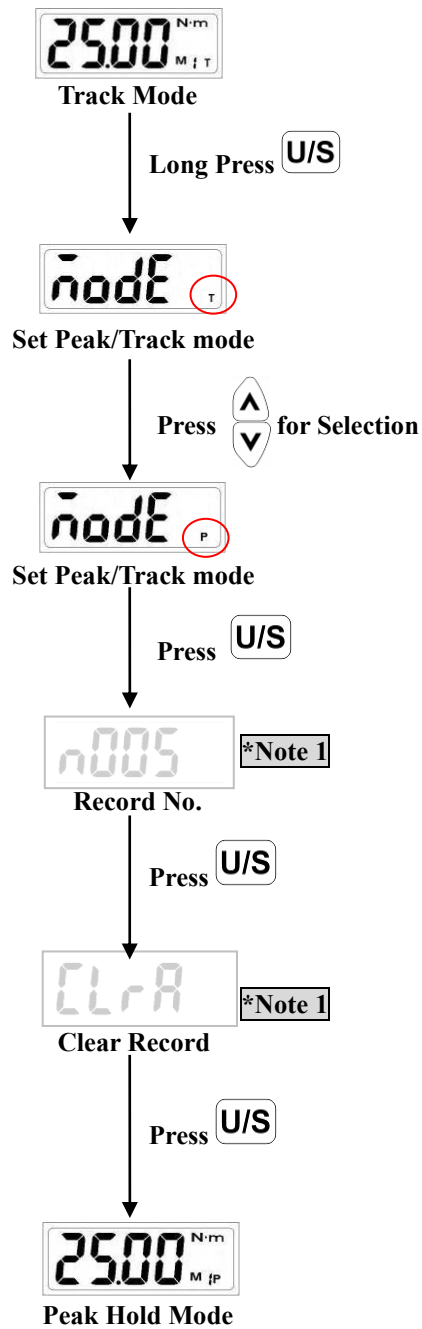

Note:

1. Please skip this procedure and continue to the next step.

TRACK MODE OPERATION

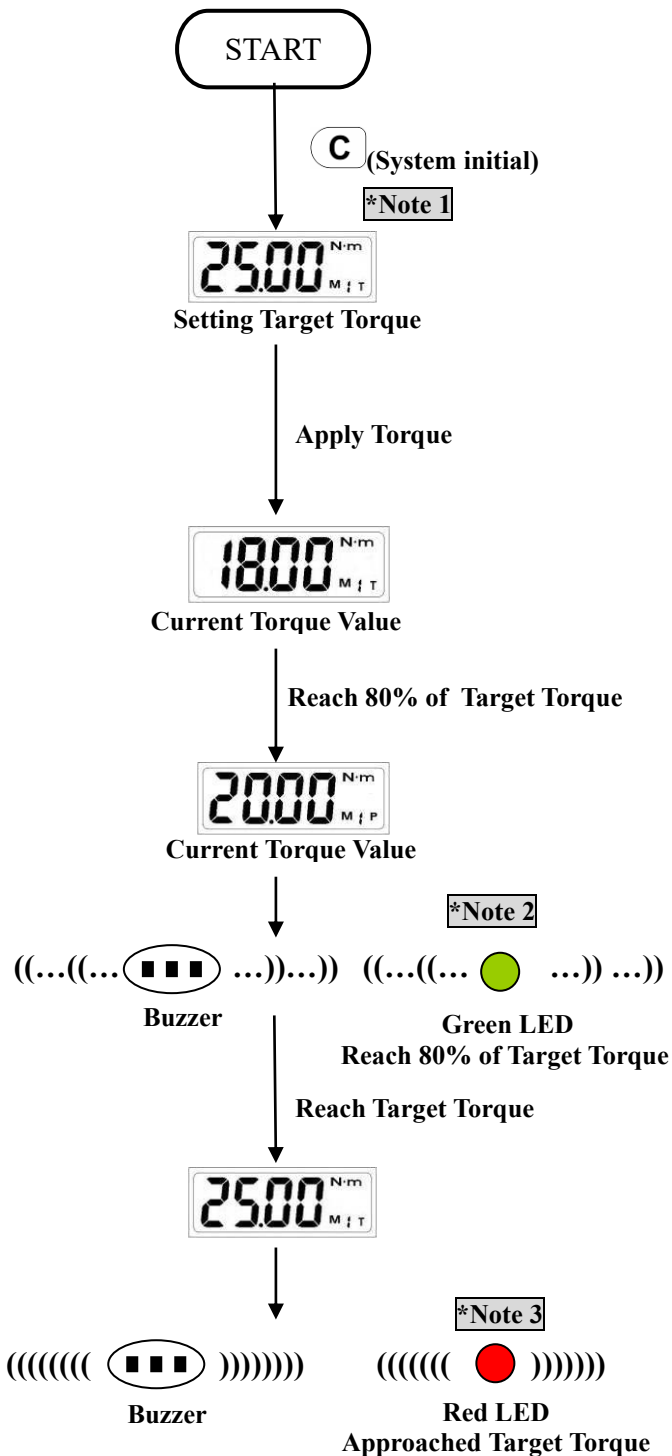

Note:

- If **Er0** is displayed, that means this wrench has applied more than 110% of torque of the spec.
- When 80% of the target torque is reached, the green LED will begin to flash and the alarm tone will beep intermittently.
- When the target torque is approached, the alarm will change to a steady tone and the green LED will stop flashing and stay on. The red LED will also illuminate.

PEAK HOLD MODE OPERATION

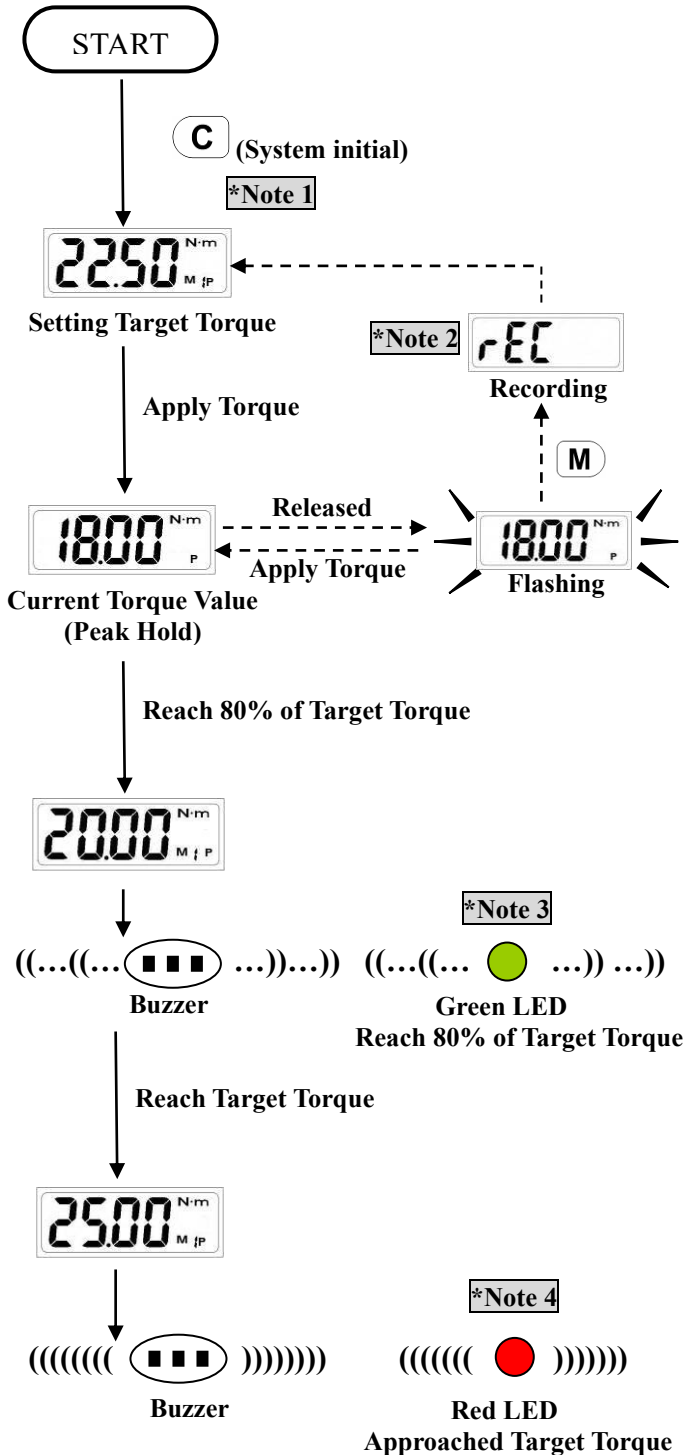

Note:

- If **Er0** is displayed, that means this wrench has ever been applied more than 110% of torque of the spec.
- If **Full** is displayed, that means the wrench's memory is full and the next value record can not be written in. Please refer the "Peak Hold Mode Recorded Value Review" section to clear the memory records.
- When 80% of the target torque is reached, the green LED will begin to flash and the alarm tone will beep intermittently.
- When the target torque is approached, the alarm will change to a steady tone and the green LED will stop flashing and stay on. The red LED will also illuminate.

Peak Hold Mode Recorded Value Review

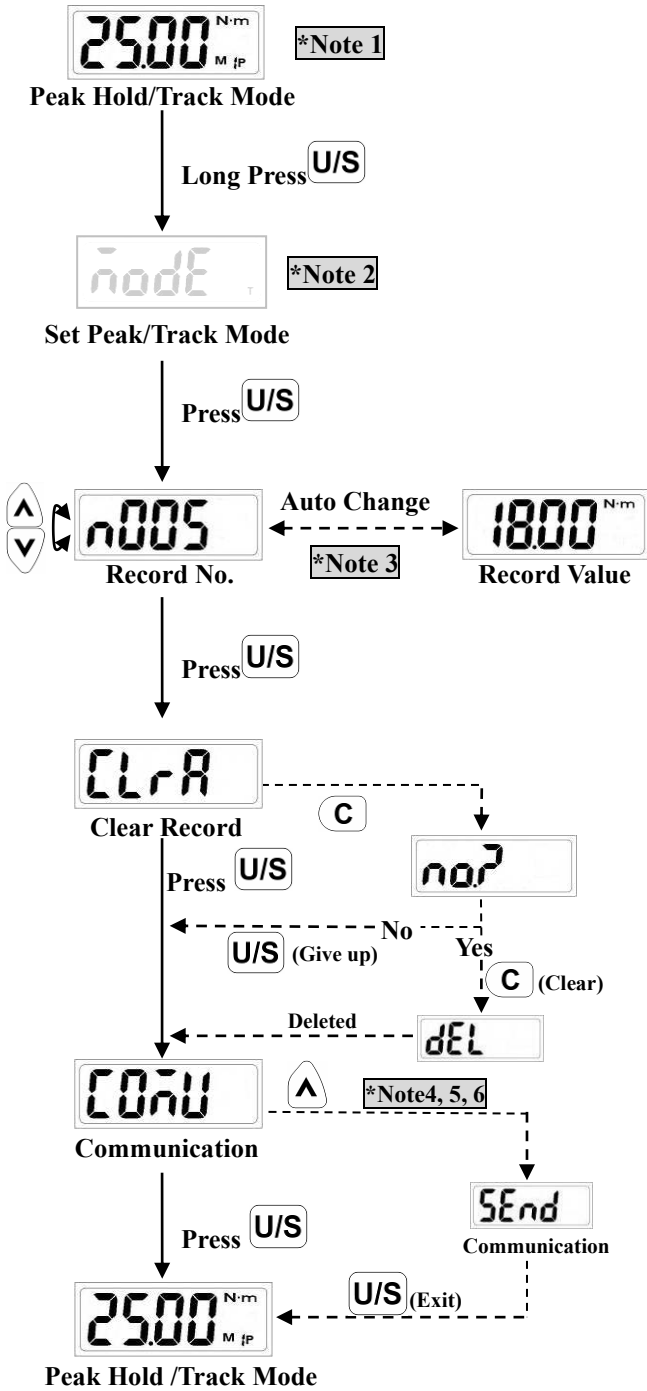

Note:

1. The “Peak Hold” mode recorded value review also can be operated from “Track” mode operation.
2. If you operate in the “Peak Hold” mode, the display will show **none**, please skip to next step.
3. If the record is empty, it will show **none**.
4. This function is not supported on all models.
5. Communication mode is for uploading record data to PC.
6. Communication mode is also for calibration of torque wrench. Please contact NAVAC technical support for more information.

MAINTENANCE AND STORAGE

ATTENTION:

1. **A one-year periodic recalibration is recommended to maintain accuracy.**
2. **Please contact NAVAC technical support for calibration details.**

CAUTION:



1. **Over-torque (110% of Max. torque range) could cause breakage or lose accuracy.**
2. Do not shake violently or drop wrench.
3. Do not use this wrench as a hammer.
4. Do not leave this wrench in any place exposed to excessive heat, humidity, or direct sunlight.
5. Do not use this wrench in water (not waterproof).
6. If the wrench gets wet, wipe it with a dry towel as soon as possible. The salt in seawater can be especially damaging.
7. Do not use organic solvents, such as alcohol or paint thinner when cleaning the wrench.
8. Keep this wrench away from magnets.
9. Do not expose this wrench to dust or sand as this could cause serious damage.
10. Do not apply excessive force to the LCD panel.
11. Apply torque slowly and grasp the center of the handle. Do not apply load to the end of handle.

BATTERY MAINTENANCE

1. When the wrench is not going to be used for an extended period of time, remove the battery.
2. Keep a spare battery on hand when going on a long trip or to cold areas.
3. Do not mix battery types or combine used batteries with new ones.
4. Sweat, oil and water can prevent a battery's terminal from making electrical contact. To avoid this, wipe both terminals before loading a battery.
5. Dispose of batteries in a designated disposal area. Do not throw batteries into a fire.

Rev. : NTW1 v1